

ASSEMBLY INSTRUCTION

SL-O72

SUN LOUNGER ADJUSTED BACK & KNEE

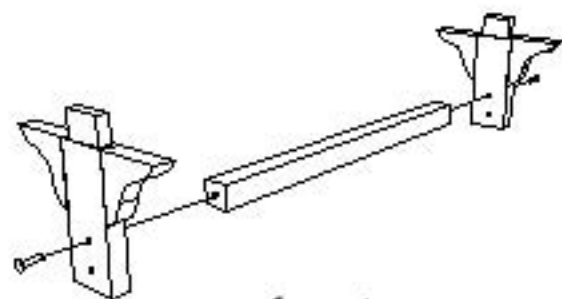

fig 1.

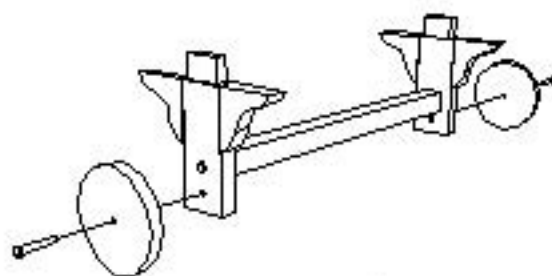

fig 2.

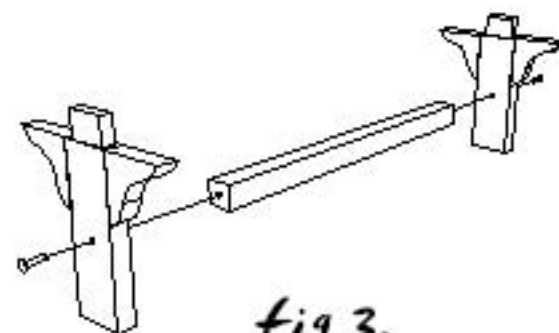

fig 3.

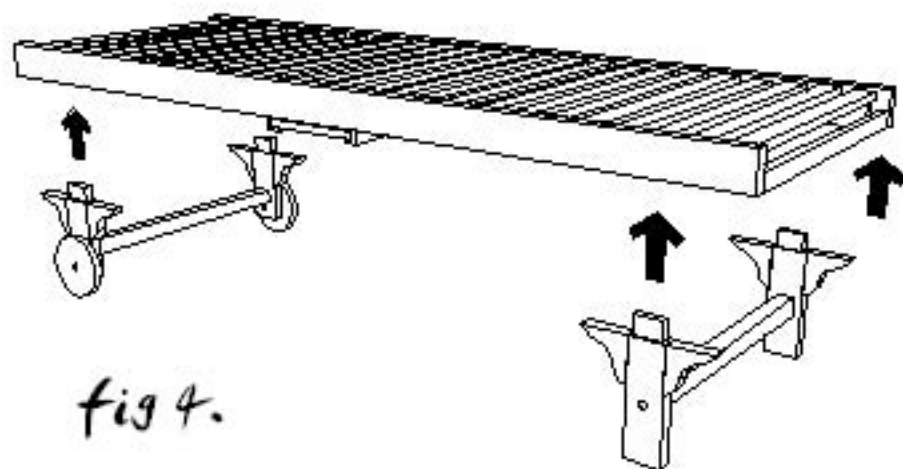

fig 4.

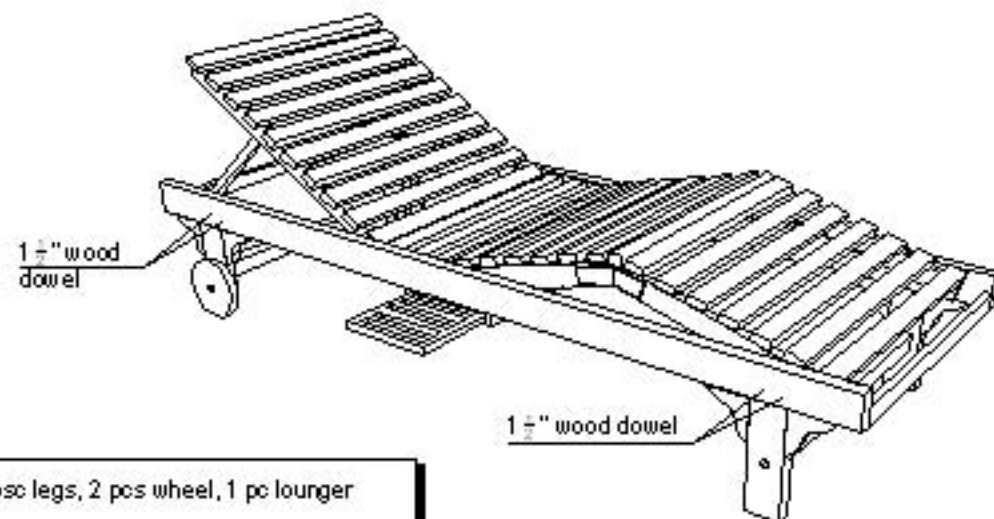

fig 6.

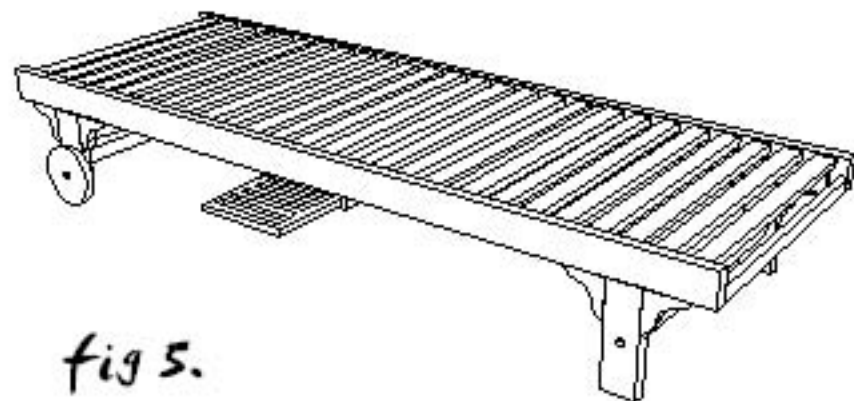

fig 5.

Parts : 4 pcs legs, 2 pcs wheel, 1 pc lounger

Hardware packs

- ▶ wood dowel for the legs
- ▶ brass clamp for the legs and the wheels

Tools requirment

- ▶ hammer (not supplied)

Assembling

1. Prepare a leg. (Fig. 1)
2. Insert the wheels into the leg. (Fig. 2)
3. Prepare the other leg. (Fig. 3)
4. Put some glue into the leg's mortise
5. Insert the legs to the lounger. (Fig. 4)
6. Put some glue around the wood dowels and insert it into the legs.
7. Clean the glue rest using a damp cloth.